



DEVELOPMENT FOR RURAL SUSTAINABILITY
DESIGN CATALOG



John DuMontelle • Jessie McKay • Shannon Monahan • Nick Reimers • Doug Richards

NORTHERN ARIZONA UNIVERSITY

Table of Contents

Introduction	3
Lesoit, Tanzania.....	3
The Maasai	3
Location	4
Bio-Battery	5
Background.....	5
Applications.....	6
Materials	6
Procedure	7
Testing and Results.....	10
Conclusion	11
Bio-Digester.....	11
Background.....	11
Applications.....	12
Materials	13
Procedure	14
Testing and Results.....	16
Conclusion	18
Appendix:	19
Rainwater Catchment.....	19
Materials	19
Procedure.....	20

Conclusion.....	21
References	27

Introduction

The purpose of this catalog is to act as a manual and template for future capstones as well as for the village of Lesoit. This manual is a living document and can be expanded upon in the future. More designs can be added as more testing and prototyping are completed. This prototype build manual will continue to grow and hopefully these designs can be implemented in rural areas. The outline for each design or prototype is the same and by using this document more designs can easily be added. All the information needed to build and replicate these designs can be found here. Materials, costs, procedures, testing, and results of previous prototyping will be kept in this catalog for easy continuation of these projects. Social, environmental, and economic assessments were created to show the impact of these designs on a given location. For the two original prototypes (the bio-battery and bio-digester) the area of location was the rural village of Lesoit, Tanzania. Development for Rural Sustainability used this location for the design assessments. Any location can be chosen for future designs and examples of these assessments will be kept in this document as well. Future capstone teams will continue to work and further develop these designs so that one day they can be built and used in rural communities.

Lesoit, Tanzania

A background of the subject village will be provided as an aid to understanding the provided assessments. Adding research and background information on the given client and location will assist in the creation of these assessments as well.

The Maasai

The Maasai are a tribal community based out of Lesoit, Tanzania. They were a nomadic people until the enforcement of borders constrained them into smaller confines. This changed their culture and now they have had to learn to live in one place. Below is a map of where Lesoit is in Tanzania. Currently, they are confined to a forested area that is being encroached by

farm land to the northwest. Their main source of income and form of nourishment is cattle. Cattle serve as a form of social status as well and are very important in the daily life of the Maasai. This affects their daily life in that their responsibilities revolve around the care of cattle. Because they have so many cattle in the village and are now a stationary tribe, the amount of manure that collects in the village could become a problem for the health of the Maasai and surrounding environment. The men in Lesoit typically are responsible for the cattle maintenance, while the women are responsible for fetching water, caring for children, and regular maintenance of the home.

The children attend school 5 days per week, similar to the structures of American education. However, schools do not have electricity to power lights. Also, most of the young boys are taken out of the education system after 8th grade to learn to become warriors, hunters and cattle farmers. The western influences have reached the village, but they have still remained intact with their roots of Maasai culture.

Location

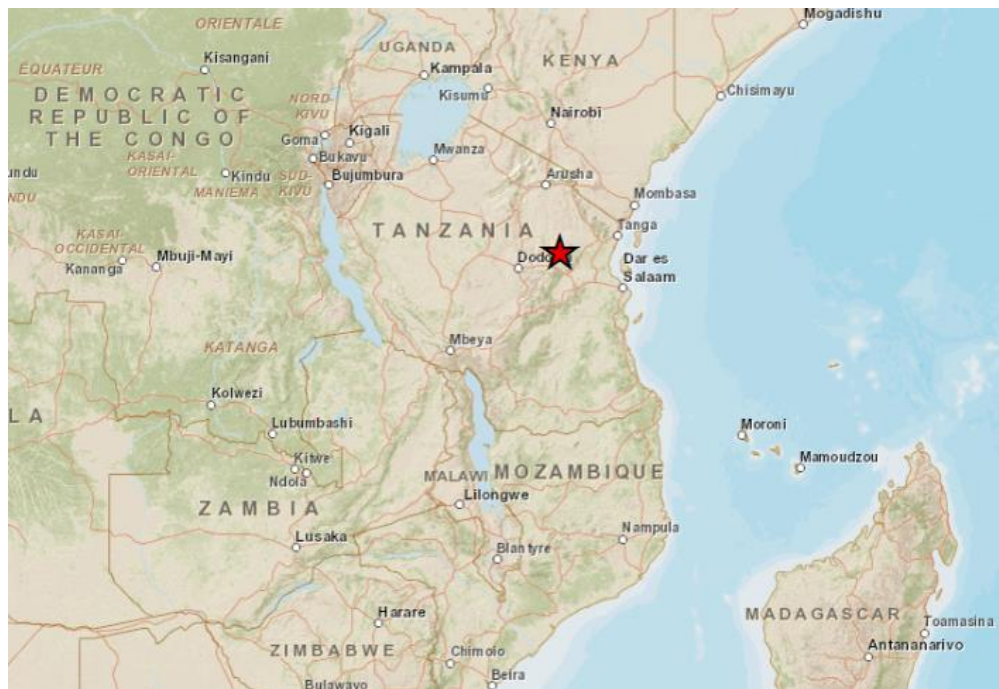

Figure 1: Location of Lesoit in Tanzania

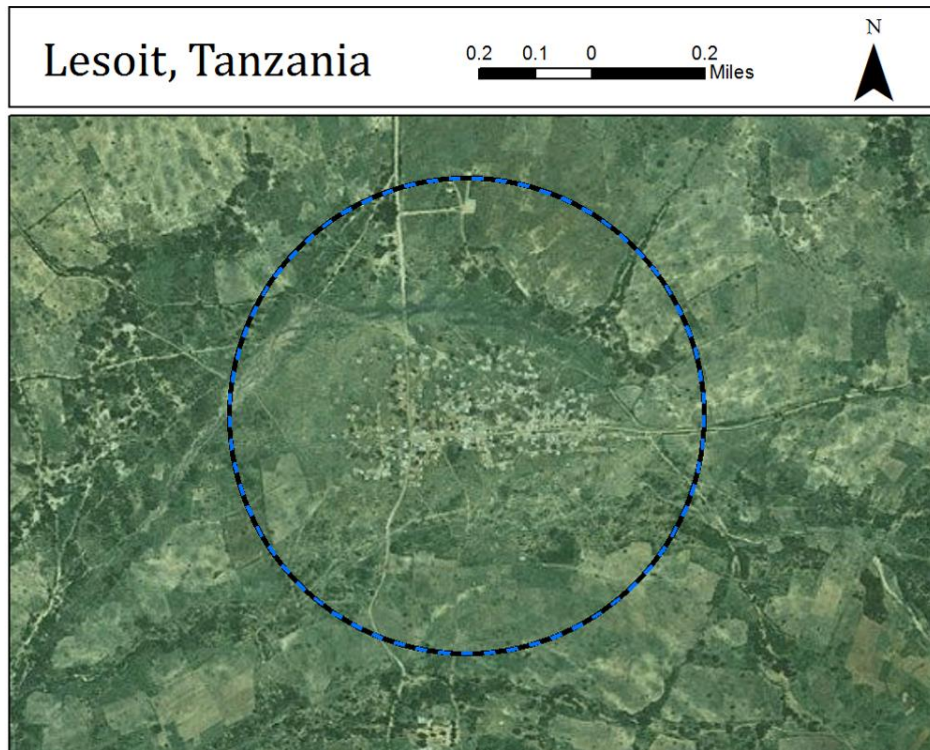

Figure 2: Village of Lesoit

Bio-Battery

This section of the catalog will provide information in regards to the bio-battery design. The procedure, materials, and results are located below. More research and design testing should be done before the bio-battery could be implemented in a rural community.

Background

A microbial fuel cell or bio-battery, is an energy storage device which utilizes microorganisms or enzymes to convert chemical energy into electrical energy. Like all batteries, a bio-battery consists of an anode, a cathode, electrolytes, and a connection. The unique feature of bio-batteries however, is of course that they exploit the features of electrically active bacteria or enzymes instead of metallic solutions.

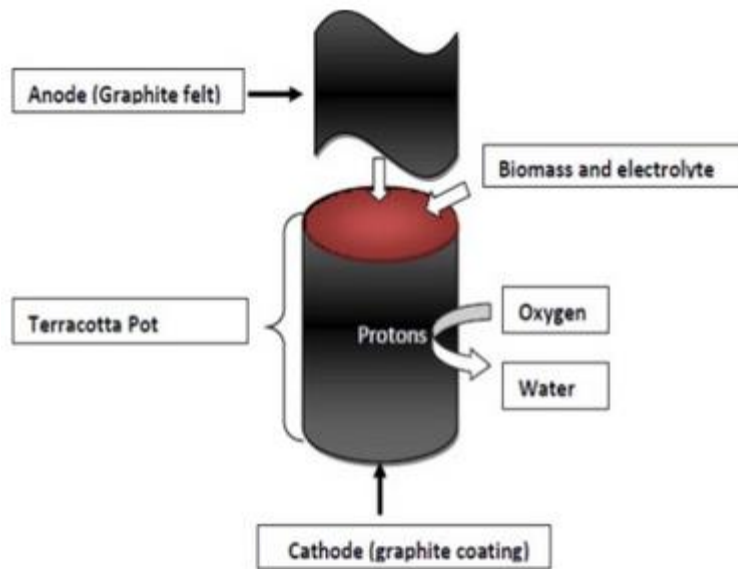

Figure 3: Diagram of Terracotta Pot Bio-Battery

Applications

Batteries, particularly bio-batteries have a myriad of applications mainly involving energy storage. Because the bio-battery can be made out of accessible materials it is a plausible solution to energy needs in rural communities. Small electronics can be powered using cheap sustainable batteries. The ultimate goal for the bio-battery is to power a cell phone. By testing different materials and variables to achieve the highest potential possible of the bio-battery, a cell phone could potentially be charged.

Materials

Below are a list of materials used to create the anode, cathode, and electrolyte solution for the bio-battery. This list only contains materials that were used in the first two phases of prototyping and are subject to change in order to

Anode:

- Carbon felt
- Zinc machine screws and nuts

- 22 gauge aluminum coated wire
- Epoxy

Cathode:

- Terracotta pot
- Polyurethane coating
- Fiberglass (resin/reagent and matting)
- 22 gauge copper wire
- Graphite paint
- Duct tape

Electrolyte:

- DI water (deionized water)
- Coca-Cola
- Cow manure

Procedure

The intent of the procedure is to be a guideline for testing and analyzing efficiencies of different bio-batteries based variables and material controls. A Design of Experimentation (DoE) analysis will be performed to help decide which combinations of parameters will be the best to test. Below the steps needed to prepare each part of the battery are listed and accompanied by pictures of the process.

Cathode:

Cut fiberglass matting to fit bottom of terracotta pot and mix fiberglass resin with reagent. Apply to the bottom of pot. Let the fiberglass dry completely and then sand down any excess fiberglass from the sides of the pot using an orbital sander. Clean the paint brushes with a paint thinner (acetone) and prepare it for reuse.



Figure 4: Fiberglass Bottom and Orbital Sander

Then tape the top rim of the pot. Cover about half of the top lip of the pot with blue painter's tape. Apply three coats of carbon graphite paint to the pots. Allow the pots to dry fully between each coat.



Figure 5: Carbon Graphite Coated Pot

Now wrap the 22 gauge copper wire around the pot (just under the lip of the pot). Use duct tape to secure the copper wire to the pot and the graphite paint. OPTIONAL: apply polyurethane coating over the graphite paint but keep the copper wire taped where it is.

Anode:

Cut a 4" by 5" piece of the carbon felt and fold it into fourths. Put one of the zinc bolts through the first two layers of the folded carbon felt. Then strip about 8" of the 22 gauge coated aluminum wire and wrap the exposed wire around the screw. Sandwich the newly wrapped screw with the remaining two layers of carbon felt. Use the nut to tightly clamp the anode together. Then cover the exposed screw with a marine epoxy to avoid any corrosion of the metal.



Figure 6: Aluminum Wire Wrapped Around Bolt



Figure 7: Epoxy Coating the Screw

Battery:

Once the epoxy dries, place the anode in the cathode pot with the aluminum wire coming out of the pot and add roughly 750 ml of the chosen electrolyte (do not add the manure yet). Perform an initial testing of the potential (voltage) of the battery. Once the voltage has been recorded, empty the battery and determine the ratio of manure to liquid solution to test. Combine and mix the solution in the pot and cap the battery. There should be an air-tight seal on the pot. The first two prototypes of the bio-battery used cellophane and rubber gloves as seals. At this point, the temperature control can begin.



Figure 8: Second Round of Battery Prototyping

Testing and Results

The first prototype was created as described above in the set-up procedures. A mixture of 236 grams of cow manure and 750 ml of DI water were used as the electrolyte solution. The outside of the terracotta pot was coated with the polyurethane.

The second round of prototyping focused on maintaining a constant temperature and lower pH. In order to lower the pH, Coca-Cola was used to try to keep the solution more acidic. This was compared to a solution of just DI water. For the temperature control, the pots were placed in a cooler with a heat lamp on them. The temperature of the pots varied slightly but were able to remain around 28 degrees Celsius. The polyurethane coating on the outside of the pot was also a variable for the second round of testing.



Figure 9: Prototypes in Cooler with Heath Lamp

Conclusion

Despite many setbacks and changes in focus, a wealth of knowledge was obtained by team DRS in regards to the operation and design of microbial fuel cells. Overcoming obstacles in experimentation is one of the most difficult tasks of engineers and scientists. If this project is developed into further capstone projects, a basis for how to build and test, as well as recorded data on operation parameters will be available.

Bio-Digester

This section will provide information about the process that creates the methane within the reactor, the procedures on how to build the DRS model, as well as testing procedures. Results will also be mentioned below.

Background

The focus of these bio digesters is turning cow manure into a usable methane gas that is suitable for a fuel source to run a generator. The process requires putting cow manure mixed with equal parts water into an airtight container to create an anaerobic environment, also known as an environment lacking oxygen. Roughly a kilogram of biodegradable material will produce about 0.4 cubic meters of gas. The first cycle of digestion takes roughly 20 days; however, once started and with daily manure added in the cycle becomes continuous. The process of methane production occurs in three steps. "In the first stage, hydrolysis, insoluble organic material and compounds like lipids, fats, proteins, and polysaccharides are broken down into soluble monomers, such as amino acids and monosaccharides, which can be used as a source of energy. This stage is enzyme driven and is carried out by strict anaerobes, such as Bactericides and Clostridia, as well as facultative bacteria, such as Streptococci"[2].

The second stage, acid formation, requires microbes breaking down the monomers, such as glucose, into volatile fatty acids that are fermented and turned into hydrogen, acetic acid, and carbon dioxide. The final step is the production of biogas by species of methanogenic bacteria of the domain archaea. These microbes break down acetate, hydrogen, and formate

and convert it into biogas. The biogas end result is made up of sixty percent methane and forty percent carbon dioxide. Two important factors that influence the efficiency of the microbes is alkalinity and temperature. "According to some literature, the optimal pH is as narrow as the range between 6.8 and 7.2, while others claim that the range is between 5.5 and 8.5. However, it is possible to control this pH range through the addition of a simple buffer, like sodium bicarbonate-also known as baking soda, or by feeding the organic substrate to the digester at an optimal rate"[2]. For the best microbial growth and methane production the temperature should be kept between 29°C and 35°C. If the temperature of the reactor drops below 16°C then the microbes will not produce any usable amount of biogas. Mixing the manure within the reactor on a daily basis will help to ensure that proper heat transfer and thorough mixing is completed, improving efficiency of the system. The leftover waste from this process is a valuable resource as well. When the water in the discharge evaporates you are left with a sterile nutrient rich fertilizer that can be used on crops or for other applications. Design of the digester is based on how much power needs to be produced and amount of manure that can be loaded daily into the digester.

Applications

The main focus for the use of the bio-digester is to be able to run an electric generator. Three other potential uses for the digester are to provide central heating, fuel for cooking, and a composting material for growing crops. Depending on the size of the reactor you can produce different quantities of power. As of right now the goal is around 15 KWh to run a water pump to pull water up from the unused well that is 102m deep. The size can be increased to accommodate other potential needs for electricity. If the methane was further filtered then it could be used to provide central heating for key buildings in the village. This would include the school and any other large buildings that are used for group activities within the village. Along with the central heating, the methane can be used for cooking in the school. The digester would not be used for heating of home or cooking in homes due to the materials and design of the huts. Any discharge from the pit is nutrient rich and can be mixed with other soils or as an additive to help in cultivating crops. Although Lesoit mainly raises cattle they could use the

discharge for personal gardens, or to sell to surrounding villages that mainly grow crops for a living. This would increase income to the village and allow for more funding for future projects.

Materials

- Reactor
 - 55 gallon steel drums
 - acrylic caulk plus silicone
 - MIG welder
 - aqua epoxy
 - 3" ABS cleanout adapter
 - ½" Flp ball valve
 - steel cutting saw blade
- Stand
 - 1 lb of exterior screws
 - wood glue
 - 4"x4" 8' wooden posts
 - ½" rebar
 - 3.5" tee hinges
 - 3" x6" mending plate
 - 2"x4" mending plate
 - wood cutting saw
- Swing Arm
 - 4x4" 8' wooden posts
 - 1lb exterior screws
 - wood glue

Procedure

The bio-reactor consists of three components: reactor, stand, and swing arm. The reactor vessel used was constructed using three 55 gallon stainless steel drums that had the bottoms cut out. These were welded together and the inner seams were sealed with silicone/caulk. Both the top and bottom were welded with the lid side facing outward. This allows for the lids to be removed for easy access and for maintenance. Both top and bottom lids have a three inch screw cap; this allows for removal of solid fertilizer from bottom and the ability to add slurry into the top. Set on the opposite side of the top lid from the screw top is a globe valve. The globe valve is used to collect the methane gas once production starts. The stand has posts that allow the digester angle to be adjusted. This alters the surface area available on the inside of the digester, which in turn affects how the microbes react.



Figure 10: Welding the Drums Together and the Valves on the Top of the Digester

Both the stand and swing arm are made from 4" x 4" post. The stand is less than a foot high on one side and stands up to four feet on the opposite side. The taller side has holes drilled between the two posts which is where a 3' stake is fed through. The swing arm is hinged to the lower side, while the higher side is where the majority of the weight is supported by the stake. The swing arm is 8 feet long and supports the reactor along the outside

edges. Procedures for constructing a bio-reactor and materials along with visual instruction are located in the appendix.



Figure 11: Stand and Swing Arm

Once the bio-reactor is complete the bottom is sealed and the cap tightened as much as possible. The angle of the reactor is set using the stake. A bucket is then used to add the 1:1 ratio of cow manure and water. The top lid is closed and each day one five gallon bucket of slurry is added. Once every week 3-5 bucket of decomposed manure is taken from the bottom. After a month continuous gas accumulation should occur. Once gas is produced it should be collected from the reactor every 2-3 days.



Figure 12: Final Digester and Backhoe Unloading Manure

Once the bio-digester is built and set up manure can start to be added. The manure is to be mixed with an equal amount of water in the reactor. This should be thoroughly mixed to ensure that the slurry is in equal parts. The reactor is filled up to the point where no more material can be added without spilling. One bucket of material is then added at least every other day with a ratio of 1:1 of cow manure and water, along with a bucket worth of material being removed from the bottom. After a month the bio-reactor will produce a steady amount of biogas that should be collected every day. The temperature is to be checked weekly and kept between 29 and 35 Celsius. Next, check that there is no leaks and that all seams are sealed. The final step is to check the valves and the pressure gauge see how much gas is accumulated in the pressure vessel. Visual instructions can be found below.

Testing and Results

There are six tests that should be conducted to determine the effectiveness of the bio-digester. These tests are conducted on the manure slurry that is added to both designs. Testing of the slurry helps to determine the potential amount of biogas that can be expected, how fast the microbes digest the waste, amount of solids within the waste, pH of the slurry, and potential toxic inhibitors to the microbes. Testing should occur on at least a weekly basis.

1. BMP (biochemical methane potential)
 - a. Used to determine the amount of organics that can anaerobic digested and turned into biogas.
 - b. Open Environmental Engineering Journal, 2012,5,1-8

2. ATA (anaerobic toxicity assay)
 - a. "Predicts likely effect of potential toxicant on biogas and CH₄ production"
 - b. ISO 13641-2:2003
3. Total and Volatile Solids
 - a. Testing for Total and Volatile Solids gives the user the quantity of solids in the slurry.
 - b. HACH Method 8276
4. Alkalinity
 - a. The pH of the slurry is a key parameter that influences the ability of the microbes to create the biogas. If the pH falls outside of the ideal range then many of the organisms that break down the waste will perish and biogas production will become stagnant.
 - b. HACH Method 8221
5. COD (Chemical Oxygen Demand)
 - a. The COD test is used to determine the amount of organic compounds within the slurry.
 - b. HACH Method 8000
6. Temperature
 - a. For ideal gas production the digester needs to remain between 29°C and 35°C
 - b. A thermometer will be used to check the temperature of the waste on a daily basis.

The bio-reactor did not generate any usable amount of gas. The reactor was set up outside without any insulation which greatly affected the performance. Due to the weather in Flagstaff, AZ there was too much of a temperature flux to produce gas. The microbes that turn the waste into methane need to operate above a temperature of 16° C, ideally maintaining a temperature between 29°C to 35°C. [5] The bio-reactor's temperature ranged from as high as 33°C to as low as 3°C. To raise the temperature and have less of a temperature flux the system should be insulated by either burying it or by covering it in an insulating material such as straw. If the reactor had produced gas, it would create roughly 2 m³ of gas every day. There is enough

power in one day of gas collection to run a 100W light bulb for 6 hours. An individual would could also use this gas for cooking purposes, capable of running a burner for 4-5 hours a day.

The reactor did produce over 410 kg of sterile fertilizer as waste. This waste is full of nutrients and has been broken down by the microbes within the waste into simple compounds. The fertilizer is excellent for growing food, and the bio-reactor produce a steady supply. One reactor could produce a minimum of 27 kg a week of fertilizer. [4] This fertilizer can also be sold for a profit in agricultural areas.

Lab and field testing was limited. Many of the devices used for the testing were defective and needed replacing. There was not enough funds in the budget to replace the broken equipment. Due to this only one reading was taken. The results taken was omitted from this report because no comparison could be made to previous conditions.

Conclusion

Despite dramatic changes in the weather, the team was able to collect a small garbage bag of gas from the bio-digester. Building the digester provided a lot of useful information for this project. Being able to control the temperature of the digester in future tests should make a big difference in any results gathered. This design can easily be continued and developed using the above procedures. One day this bio-digester can be implemented in a rural community and used to mitigate animal waste as produce methane.

Appendix A:

Supplemental information for the waste management designs is located in this section.

Rainwater Catchment

A rainwater catchment system was designed to aid in the water use of the bio-battery and bio-digester for areas with limited amounts of water. The average rainfall for Lesoit, Tanzania is between 500-600mm/year or 20-24 in/year. The specifications that this design must abide by include:

- The structure must not add contaminants to the rainwater collected
- Must not be more than 3 meters tall, for aesthetics and cleaning capability
- Must be usable by anyone over the age of 10, especially women
- Must keep out vectors (insects, cows, birds, etc.)
- Design life > 10 years
- Must maximize the water collected (minimize spillage), spillage → 0
- Must be cheap (< \$7500)

Materials

The necessary materials that I propose we use to implement the design are as follows:

- 119.6 m² Metal Roofing material (Classic Rib Metal)- \$0.66/sf = \$402.09 [4]
- Metal Roofing is recommended for use in the 40 CFR Rainwater Catchment Regulations for Water Quality
- Wood Supports (2-2X4's per support)- 4 supports- \$3.52/piece = \$28.16 [5]
- Concrete Foundation to hold wood beams in place (V=0.16965m³) Price= difficult to approximate
- 6000 Liter Tank - \$700.00 [6]
- PVC pipe (further analysis needed)
- Rain roof gutter (8 m) - \$25.29 [7]
- Butterfly Valve - Depends on sizing of the PVC pipe

- 3 oz. Calk \$9.95

Procedure

In order to prototype this design, we suggest that we take measurements of the amount of rain that Flagstaff receives, and construct the design below.

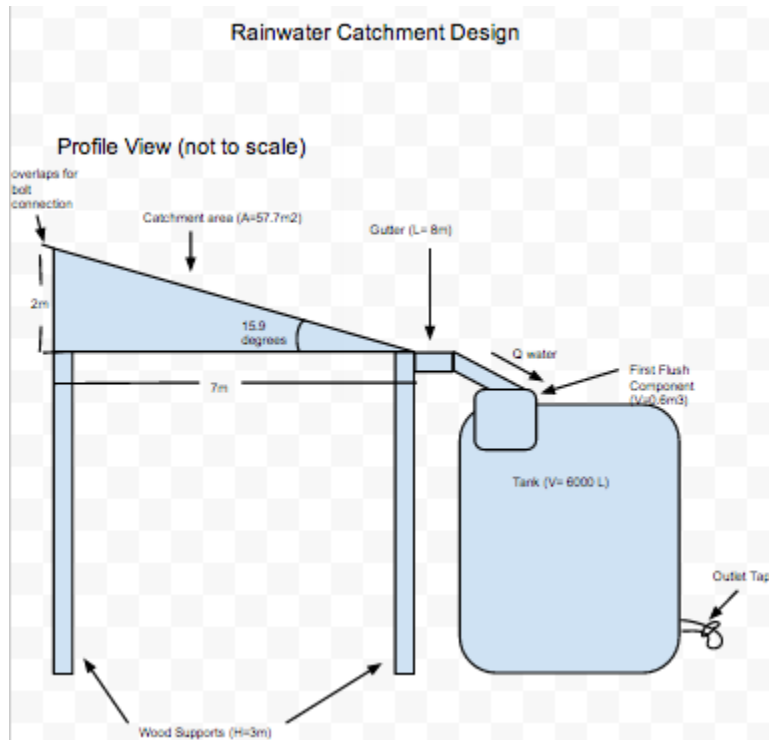

Figure 13: Rainwater Catchment Design

To implement this prototype in Flagstaff, one needs to obtain the materials listed above. This design could be implemented in a rural area, such as Trotta's farm, in an area without tree cover, or in a backyard near NAU. The first step is to construct the roof. Create the 15.9 degree angle using wood supports and sheet metal. Then, one would attach the gutter by bolting it to the roof. The next step is to lift and nail in the roof to the 3m wood supports. This way, it is easier to fully attach the gutter by nailing it to the wood supports. Finally, one is able to attach the extended gutter that will allow the flow of water to go into the collection tank. The first flush system can be ignored in this design, because the water being used does not have to pass any standards of water quality. Therefore the water can be collected in the 6000L tank, and one will be able to use the tap to get water from the tank. A hole to put the tap or the butterfly

valve in will need to be drilled. This hole can be 3 cm in diameter, or just big enough to fit the valve in. The remaining space that the tap does not fill, can be filled with calk, so that the design does not allow losses of water. From start to finish, this design can now be used.

Conclusion

The rainwater catchment design is to be implemented in Lesoit, Tanzania as a means to supplement the water demands for the bio-digester and the bio-battery. However, this design, like the others can be implemented in other rural communities who could use energy or more water sources. With this design and simplified instruction catalog, team DRS hopes to make a difference in rural villages through resource renewal.

Bio-Reactor Visual Instruction

All units shown below are in US customary units.

Reactor

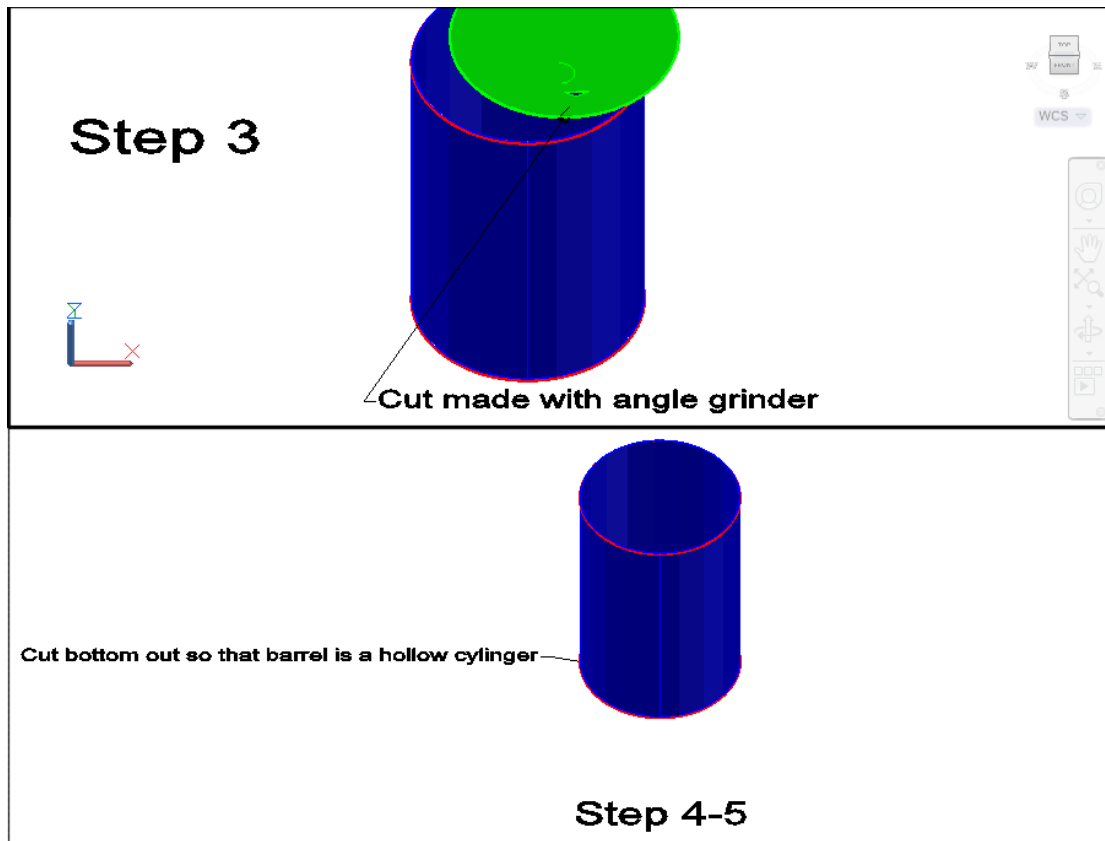

Figure 14: Step 3,4,5

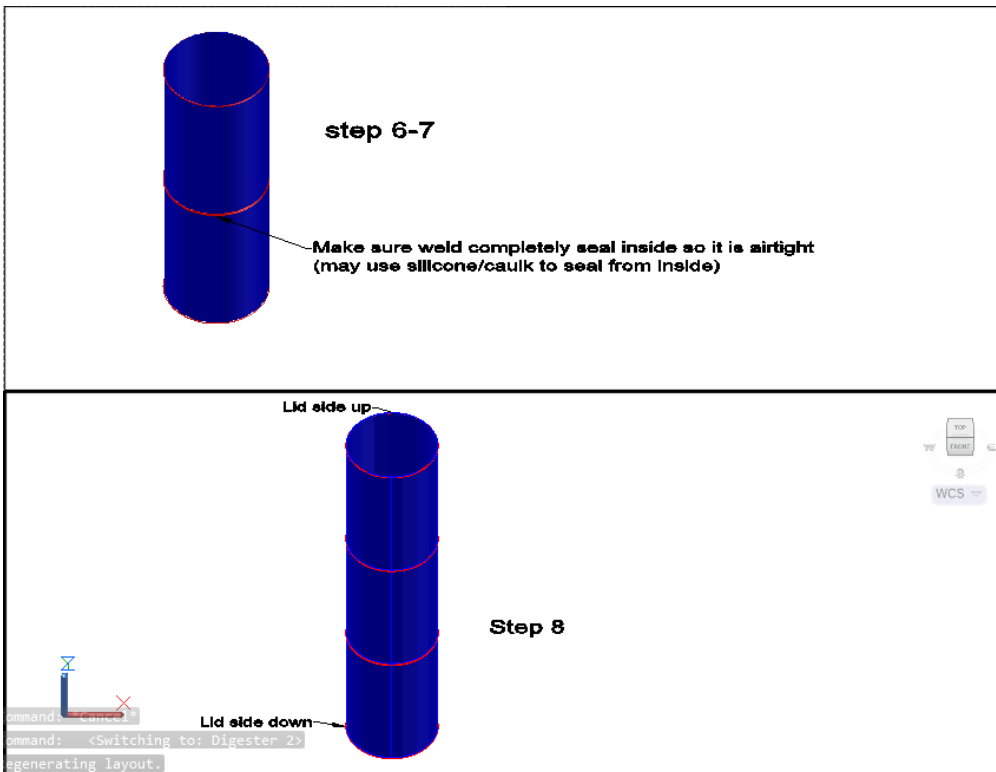

Figure 15: Steps 6, 7, 8

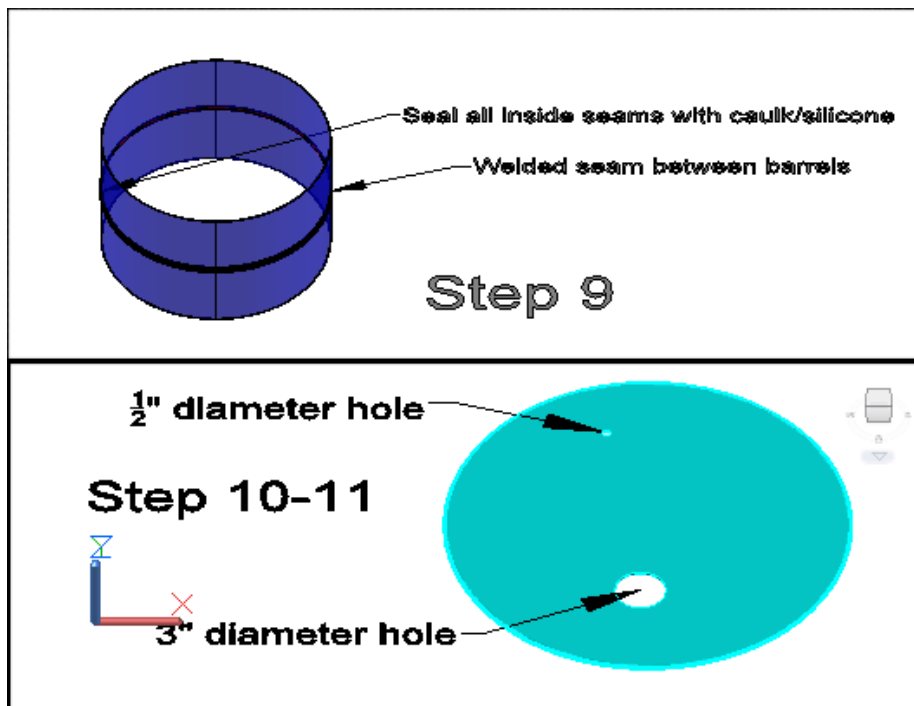

Figure 16: Steps 9, 10, 11

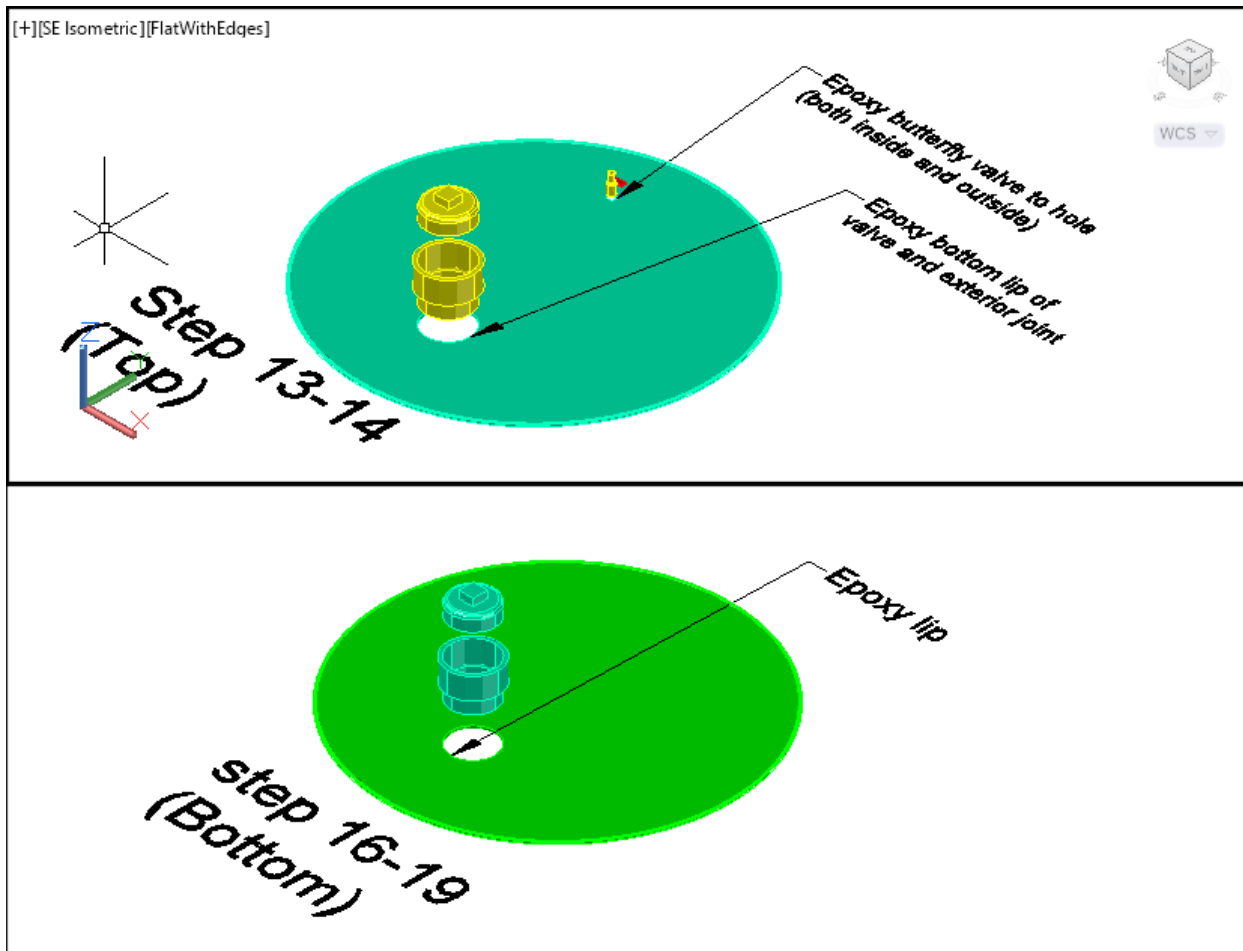

Figure 17: Steps 13, 14, 15, 16, 17, 18, 19

Reactor Stand

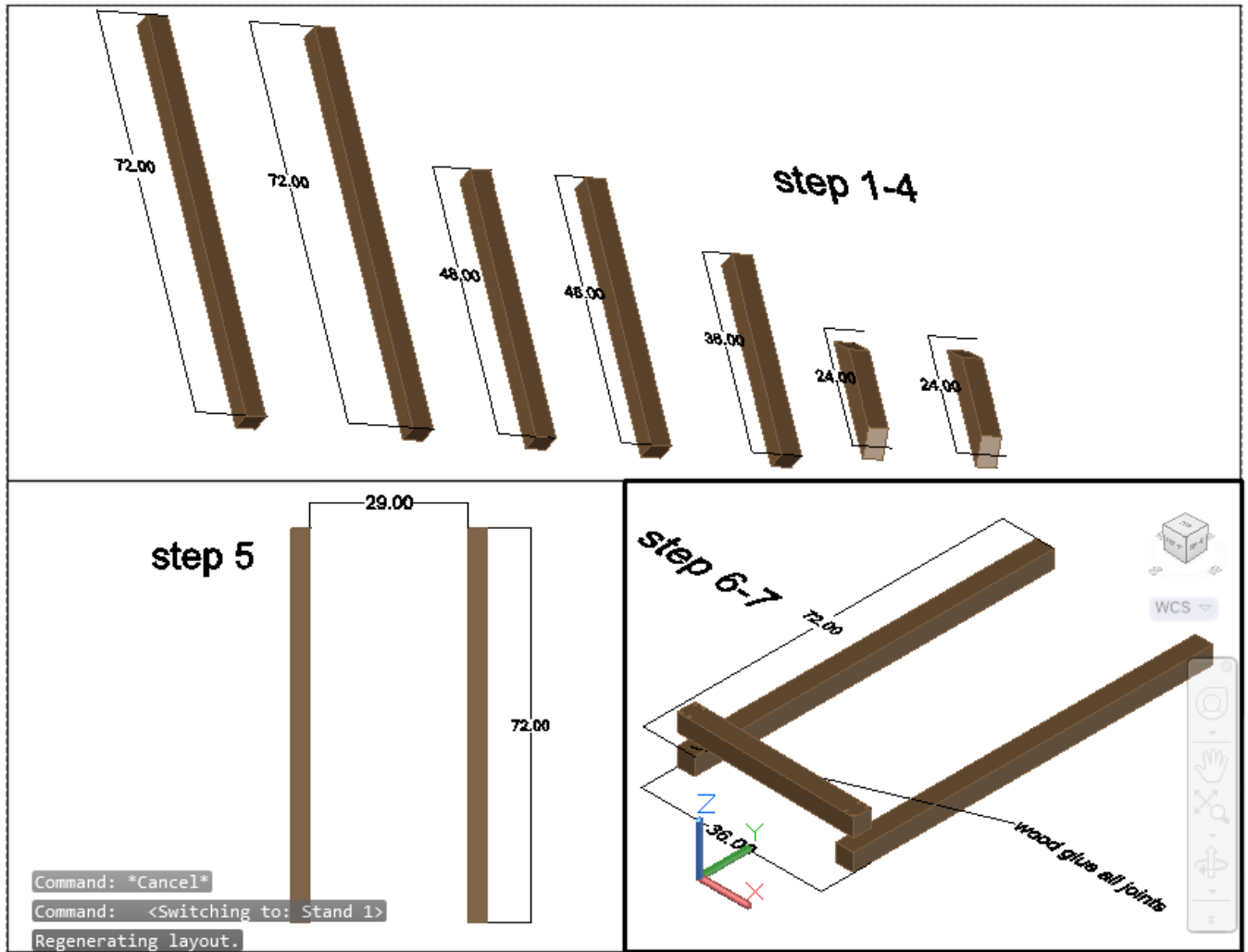

Figure 18: Steps 1, 2, 3, 4, 5, 6, 7, 8, 9

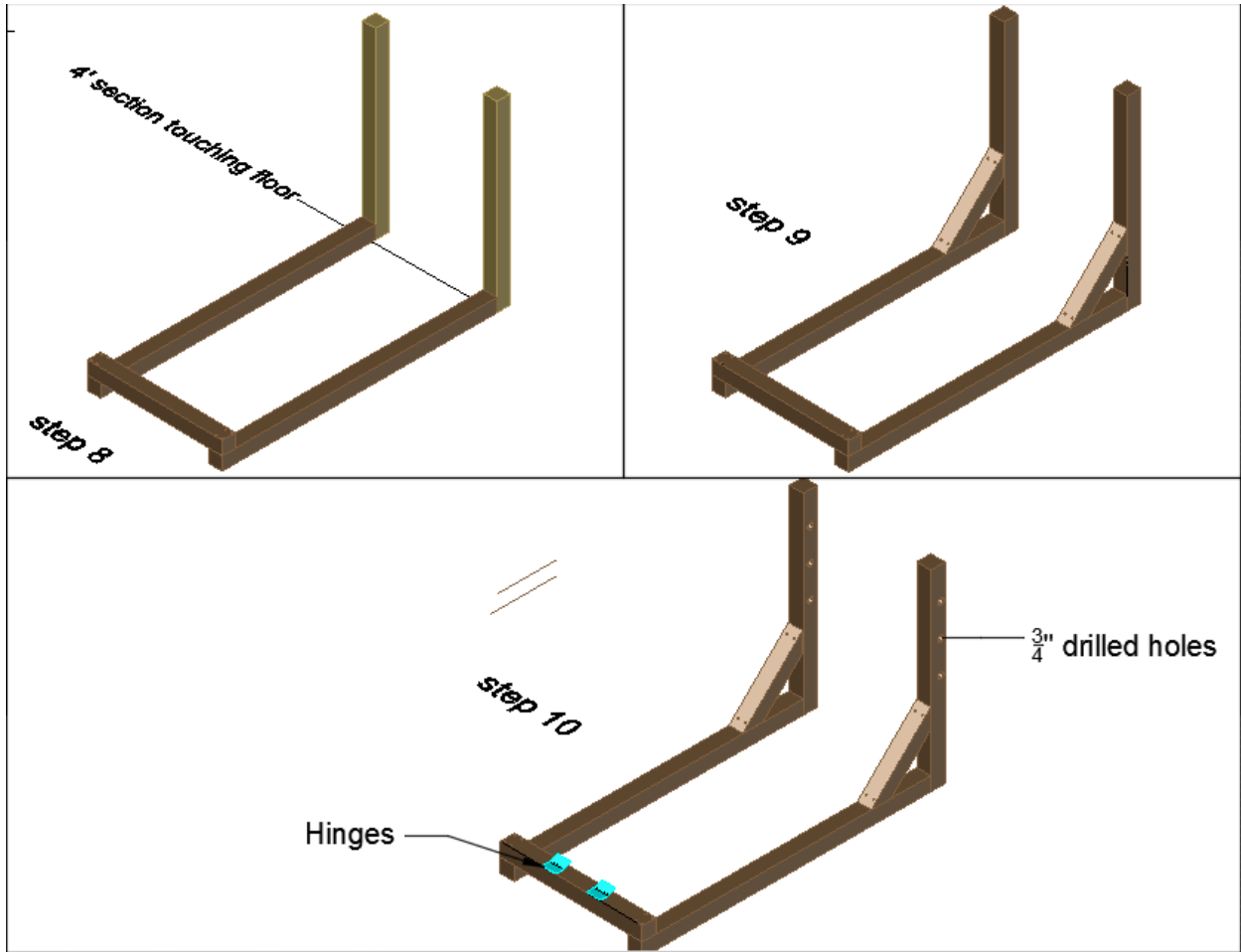

Figure 19: Steps 8, 9, 10

Swing Arm

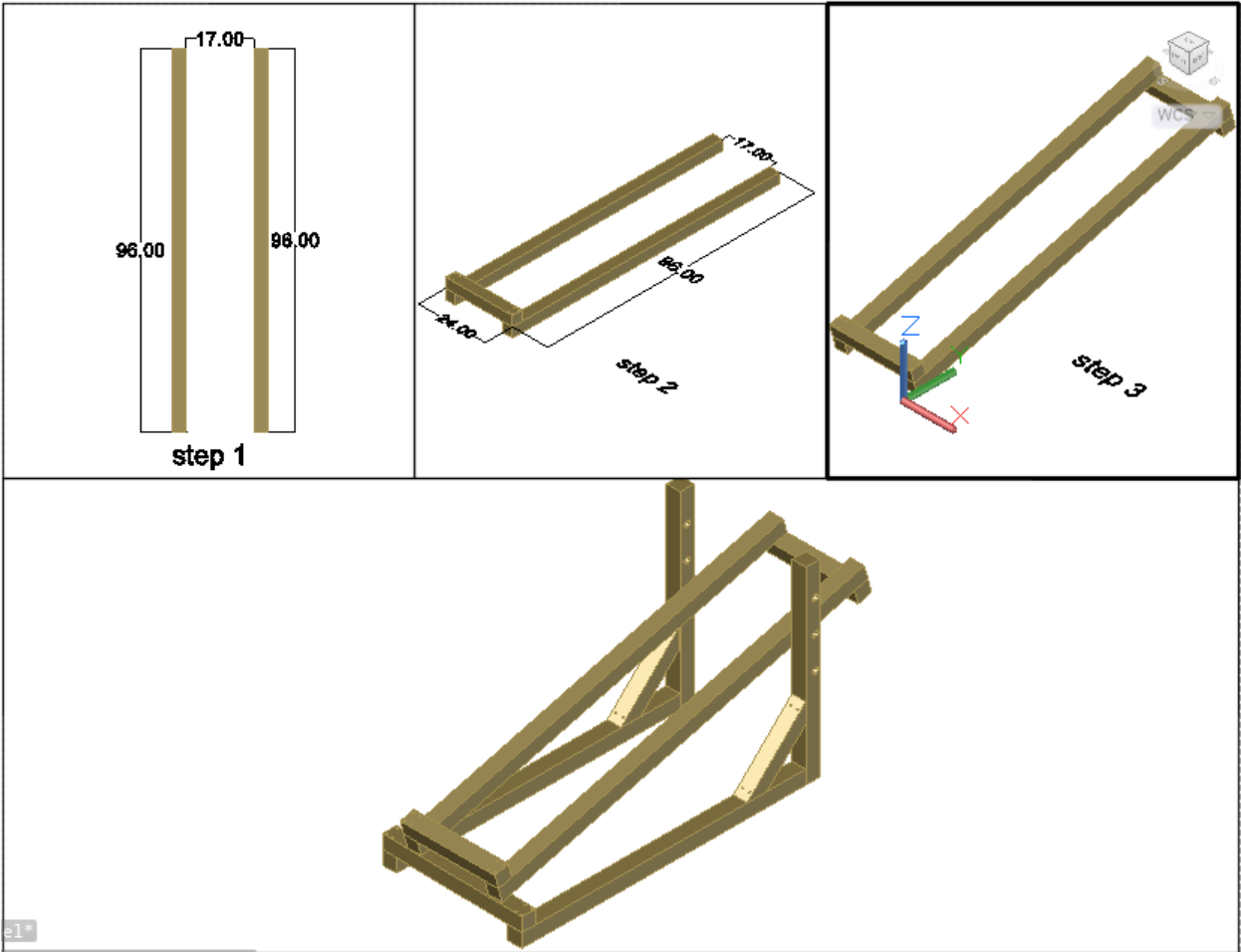

Figure 20: Steps 1, 2, 3

Final Product

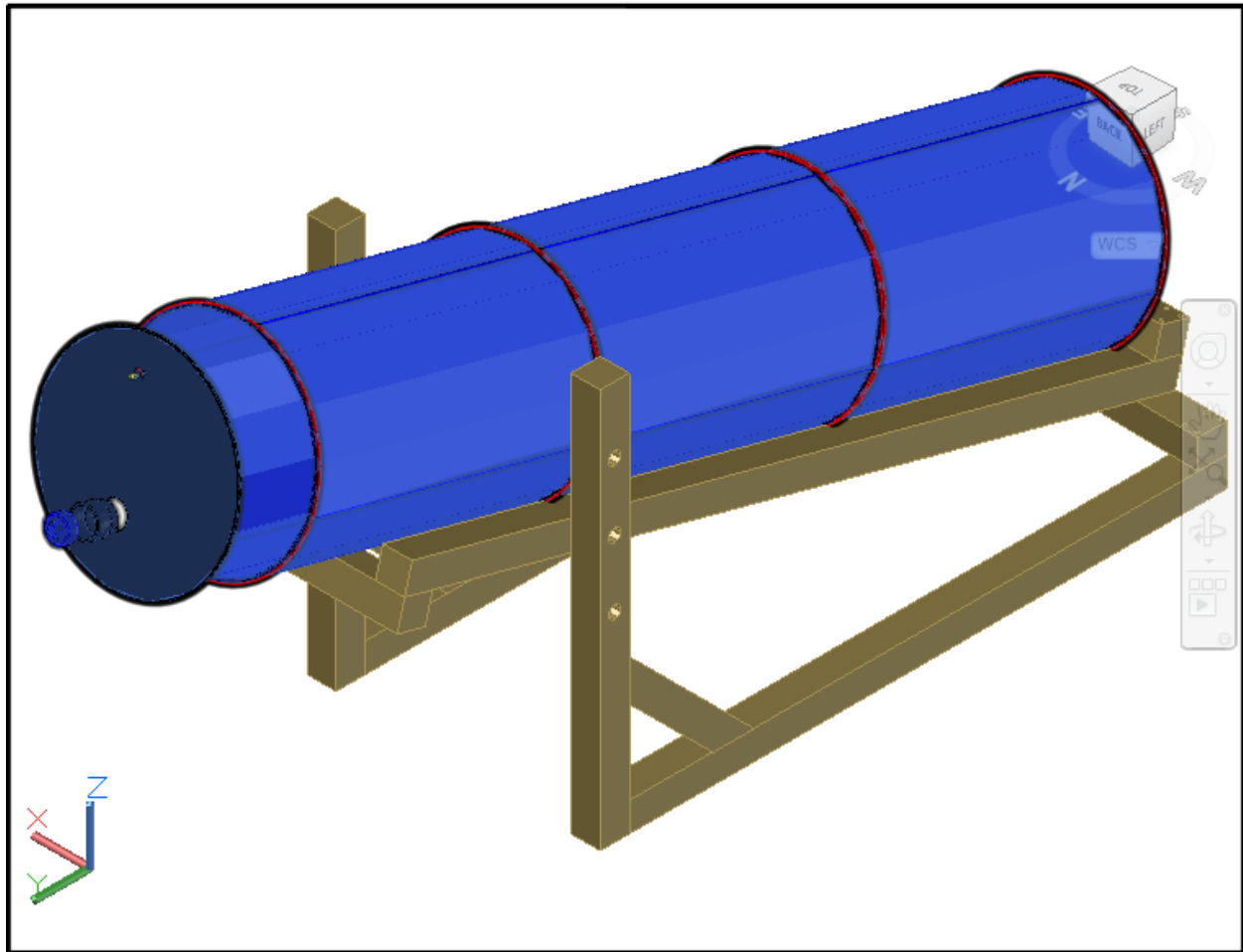

Figure 21: Final Product

References

[1] <http://onlinelibrary.wiley.com/doi/10.1002/ad.656/pdf>

[2] *Biomethanation: The Science Behind Biogas Digesters* [biomethanation]. Available: <https://sites.google.com/a/owu.edu/biogas-digesters-a-review-of-the-science-benefits-and-drawbacks/biomethanation-the-science-behind-biogas-digesters>.

[3] <http://www.greenoptimistic.com/2008/03/14/how-to-build-a-backyard-biogas-plant/#.VFkuKPnF-So>

[4] <http://imetal.net/cart/classic-rib-metal-panel.html?gclid=Cljhj-f738ECFUhffgodbl8AQA>

[5] <http://www.homedepot.com/p/Unbranded-2-in-x-4-in-x-10-ft-Standard-Better-Kiln-Dried-Heat-Treated-Spruce-Pine-Fir-Lumber-161659/100077951>

[6] http://www.alibaba.com/product-detail/Rotomolding-Water-Storage-Tank_491857523.html

[7] <http://www.homedepot.com/p/Amerimax-Home-Products-5-in-x-10-ft-Galvanized-Steel-K-Style-Gutter-White-3200700120/100013964?N=5yc1vZc5qrZ12kxZ1z0t1o6>

[8] (March 14, 2008). *How to Build a Backyard Biogas Plant*. Available: <http://www.greenoptimistic.com/2008/03/14/how-to-build-a-backyard-biogas-plant/#.VF0E5PnF98E>.

[9] (2014). *How To Build a 100 Cubic Foot a Day Methane Gas Plant*. Available: [http://www.motheearthnews.com/renewable-energy/methane-gas-zmaz71ndzgoe.aspx#axzz3IPD0Km8w](http://www.motheearthnews.com/renewable-energy/methane-gas-zmaz71ndzgoe.aspx#axzz3IPD0Km8w;);